

# MECHATRONICS

## 4 AXIS MICRO STEPPER MOTOR DRIVER DATASHEET

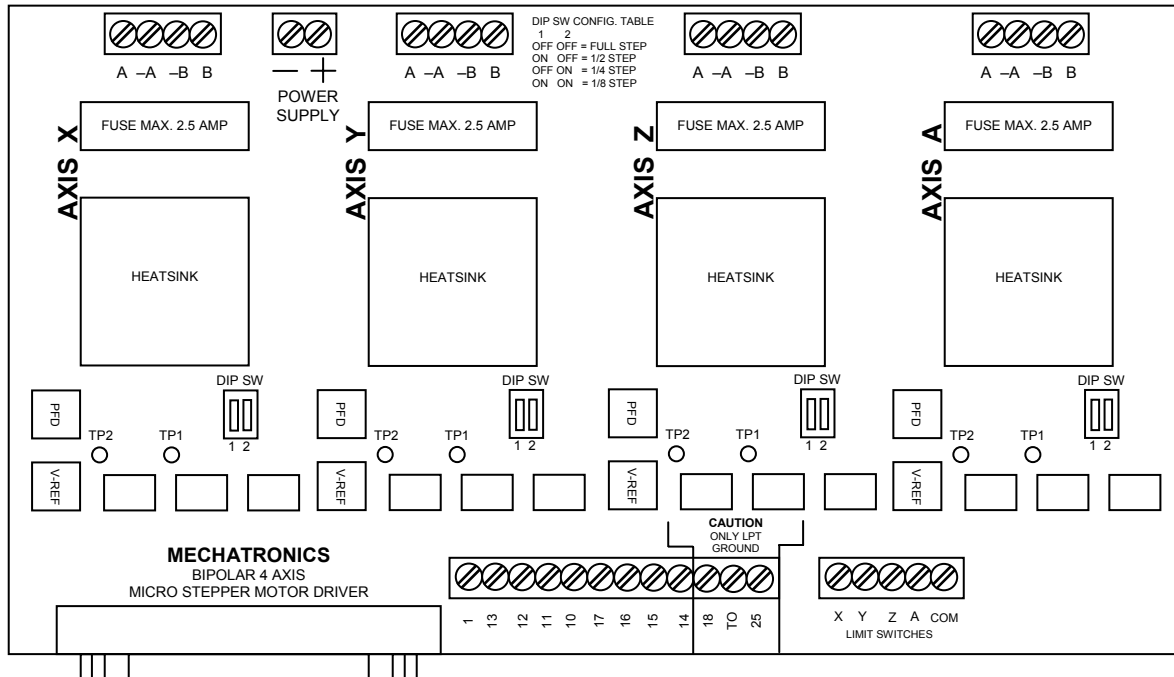

### FEATURES

- Two phases bipolar driver (PWM Technology)
- Resolution: Full 1/2, 1/4, 1/8, selectable via DIP switch per axis, you can get 1600 steps per revolution with a 1.8° common stepper motor
- Individual enable/disable **via hardware**, using optocoupler input terminal (it can be used as axis limit switch), per axis
- Adjustable stepper motor current via potentiometer on board
- Adjustable PFD (Percent Fast Decay)
- DB25 male connector on board for PC parallel port
- All inputs signals are optocoupled for PC parallel port protection
- Full access to all unused DB25 port pins via terminal block
- 24VDC input voltage
- Individual heatsink per axis
- 4 Wire, 6 Wire and 8 Wire (NEMA17, NEMA23 and NEMA34) stepper motors can be used with this driver board
- Fuse per axis integrated for driver board protection
- 2.5 Amps/phase per axis

## PARALLEL PORT CONNECTION TO DRIVER BOARD

A DB25 male-female extension should be used to interconnect the driver board to your PC; this connection should have no any kind of adapters, no hubs.

If your computer is a laptop it is probably you do not have access to a parallel port, if that is the case you must install a PCMCIA parallel port card. The DB25 connector pin description of the driver board is the following:

DB25 CONNECTOR PIN NUMBER	USE IN DRIVER BOARD	USE IN PROTOTYPING TERMINAL BLOCK
1		Strobe
2	Step X	
3	Dir X	
4	Step Y	
5	Dir Y	
6	Step Z	
7	Dir Z	
8	Step A	
9	Dir A	
10		ACK
11		Busy
12		Paper Empty
13		Select
14		Auto Feed
15		Error
16		Init
17		Select in
18-to-25	Ground for Step and Dir	LPT Ground

## DIP SWITCH RESOLUTION SELECTION

The dip switch on board is used in the driver step resolution configuration. i.e., If you have a 1.8° stepper motor and select full step, you will get 200 steps each 360° turn, with a 1/8 step resolution you will get 1600 steps each 360° turn.

You can change the step resolution when the power is ON or OFF without fear of risk the driver board.

Resolution	DIP SWITCH POSITION		Steps number per 360° turn
	1	2	
Full step	OFF	OFF	200
1/2 step	ON	OFF	400
1/4 step	OFF	ON	800
1/8 step	ON	ON	1600

## BASIC SCHEMATICS OF STEPPER MOTOR

### 4 WIRE STEPPER MOTOR DIAGRAM

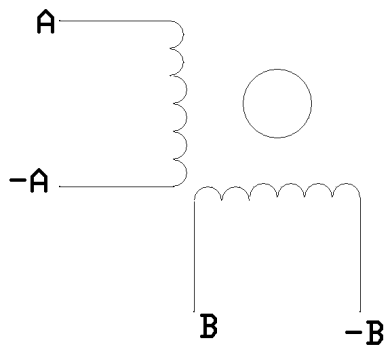

Connect each wire to the terminal block as shows you. i.e., The **-B** wire of the stepper motor must be connected to the **-B** screw in the terminal block.

### 6 WIRE STEPPER MOTOR DIAGRAM (SERIES WIRING)

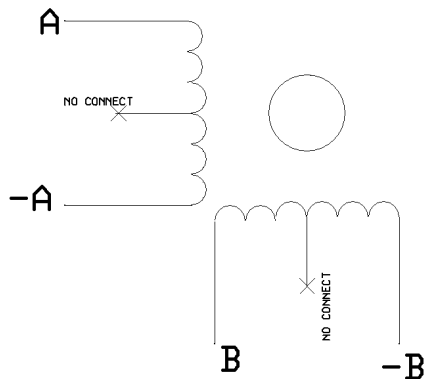

Do not connect the middle wire of each coil; don't forget to insulate the connection and the middle wire.

Connect each wire to the terminal block as shows you. i.e., The **-B** wire of the stepper motor must be connected to the **-B** screw in the terminal block.

### 8 WIRE STEPPER MOTOR DIAGRAM (SERIES WIRING)

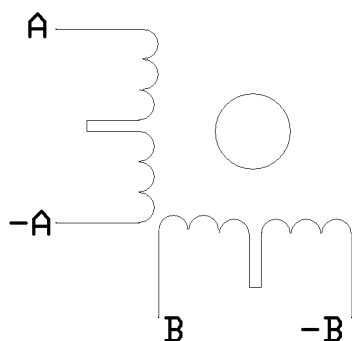

Both centre wires of each coil must be connected; don't forget to insulate the connections.

Connect each wire to the terminal block as shows you. i.e., The **-B** wire of the stepper motor must be connected to the **-B** screw in the terminal block.

It is suggested you must have the diagram of the stepper motor that you are going to use; this will help you to avoid short circuits, damage the board or something similar.

Do not worry if you have not the diagram, you can get the properly configuration with a multimeter, in the ohm section, take a wire as reference, then, measure the resistance between this and the other wires, when you get a smaller resistance (less than 10 ohm) you have found a coil (Most of the stepper motors has a resistance lower than 10 ohm per coil).

**! WARNING !**  
**DO NOT CONNECT OR DISCONNECT ANY MOTORS OR ANY MOTOR'S LEAD WHILE POWER IS ON, THE DRIVER BOARD CAN BE DAMAGED IMMEDIATELY**

### ADJUSTMENT OF THE STEPPER MOTOR CURRENT

Every axis current must be adjusted in the V-REF potentiometer using a multimeter in the volts section otherwise use a voltmeter; connect the black test probe to the power supply GND, make sure the power supply is plugged to the driver board and its ON, the red test probe to the Test Point 1 (TP1), adjust the potentiometer until you get the desired current. Follow this formula:

$$V_{REF} = 2 * (\text{desired current})$$

i.e., For a desired current of 1.8 Amp you will adjust the V-REF potentiometer until you get 3.6VDC in the voltmeter.

There is no problem if you adjust the V-REF potentiometer when the power is on and the stepper motor is connected to the board, just be sure that current increase slowly. If you realize an overheating in the motor it means that the motor's current is high.

**NOTE: THE MAXIMUM VOLTAGE VALUE FOR VREF IS 5.0VDC PER AXIS**

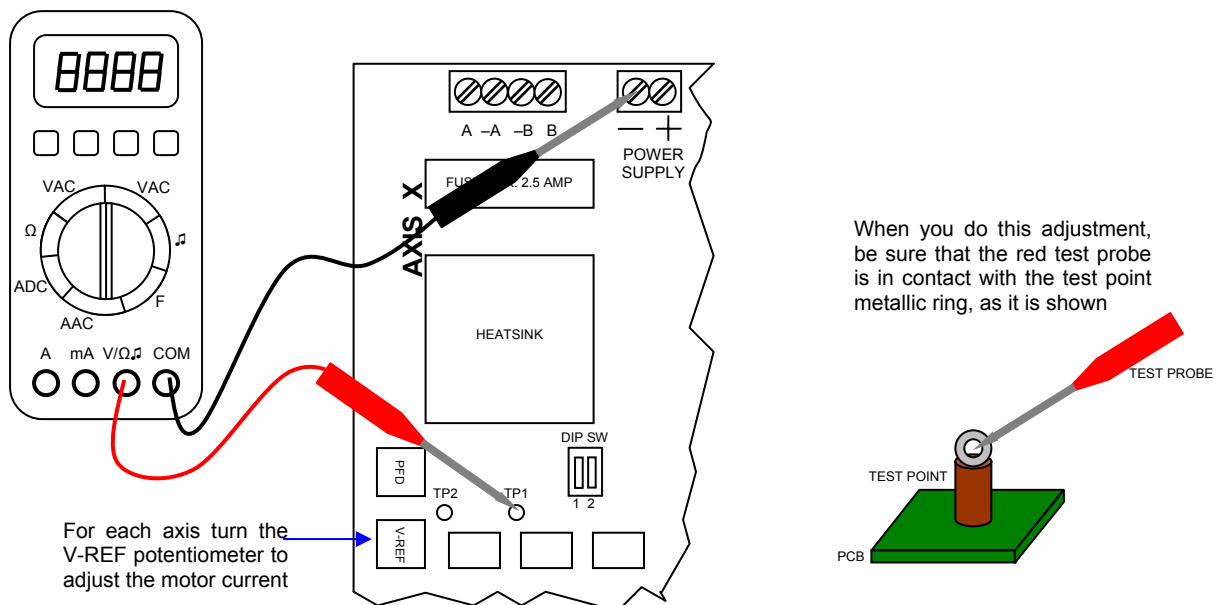

If you use 6 or 8 wire motor use the series wiring, it reduces the amperage rating in 50%. i.e., A 3Amp motor wired in this way should be considered as 1.5Amp motor.

Every axis can give you 2.5Amp per phase. If your application does not need the 100% of the torque you can adjust the current to a conservative value (70-80%), this can give you good result without need a fan cooling.

## ADJUSTMENT OF PFD VOLTAGE

The voltage in TP2 is adjusted by the PFD (Percent Fast Decay) potentiometer, this voltage tells the driver the output current decay, when the PWM circuit switches the control current, you can adjust the PFD voltage value in order to decrease the resonance noise in the stepper motor.

It is normal that you hear a little resonance noise in the motors, this is caused by the current pulse control, in fact, is imperceptible in high quality motors. For most of these stepper motors PFD = 2.5VDC is a good reference to make any adjustment.

There is no risk of damage if you adjust the PFD voltage when the power is on and the stepper motor is connected to the board.

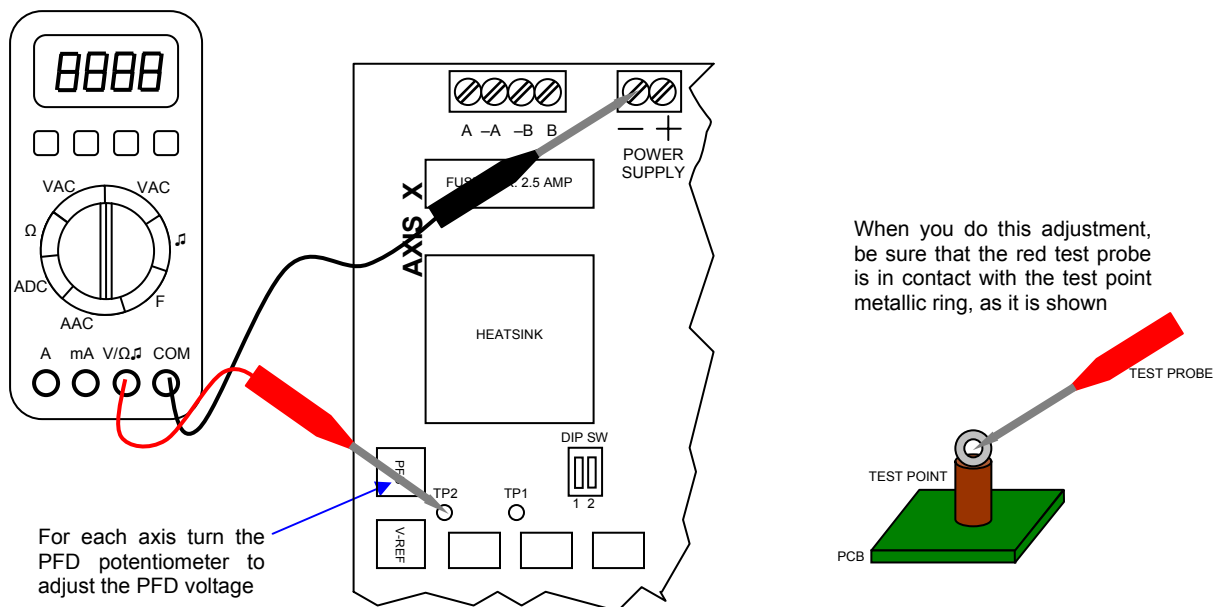

## **; WARNING !**

- **DOUBLE CHECK ALL CONNECTIONS BEFORE TO CONNECT TO POWER SUPPLY, THEN, TURN ON THE POWER SUPPLY**
- **DO NOT CONNECT OR DISCONNECT ANY MOTOR OR ANY MOTOR'S LEAD WHILE POWER IS ON, THE DRIVER BOARD CAN BE DAMAGED IMMEDIATELY**
- **RECOMMENDED POWER SUPPLY:  
24VDC@7A**
- **MINIMUM POWER SUPPLY:  
12VDC@7A**
- **MAXIMUM POWER SUPPLY:  
32VDC@7A**
- **RECOMMENDED FUSE 2.5AMP MAX.**

- **LTP GND AND POWER SUPPLY GND ARE INDEPENDENT, FOR ANY REASON THESE TERMINALS SHOULD NOT BE INTERCONNECTED**

# BASIC CONNECTION

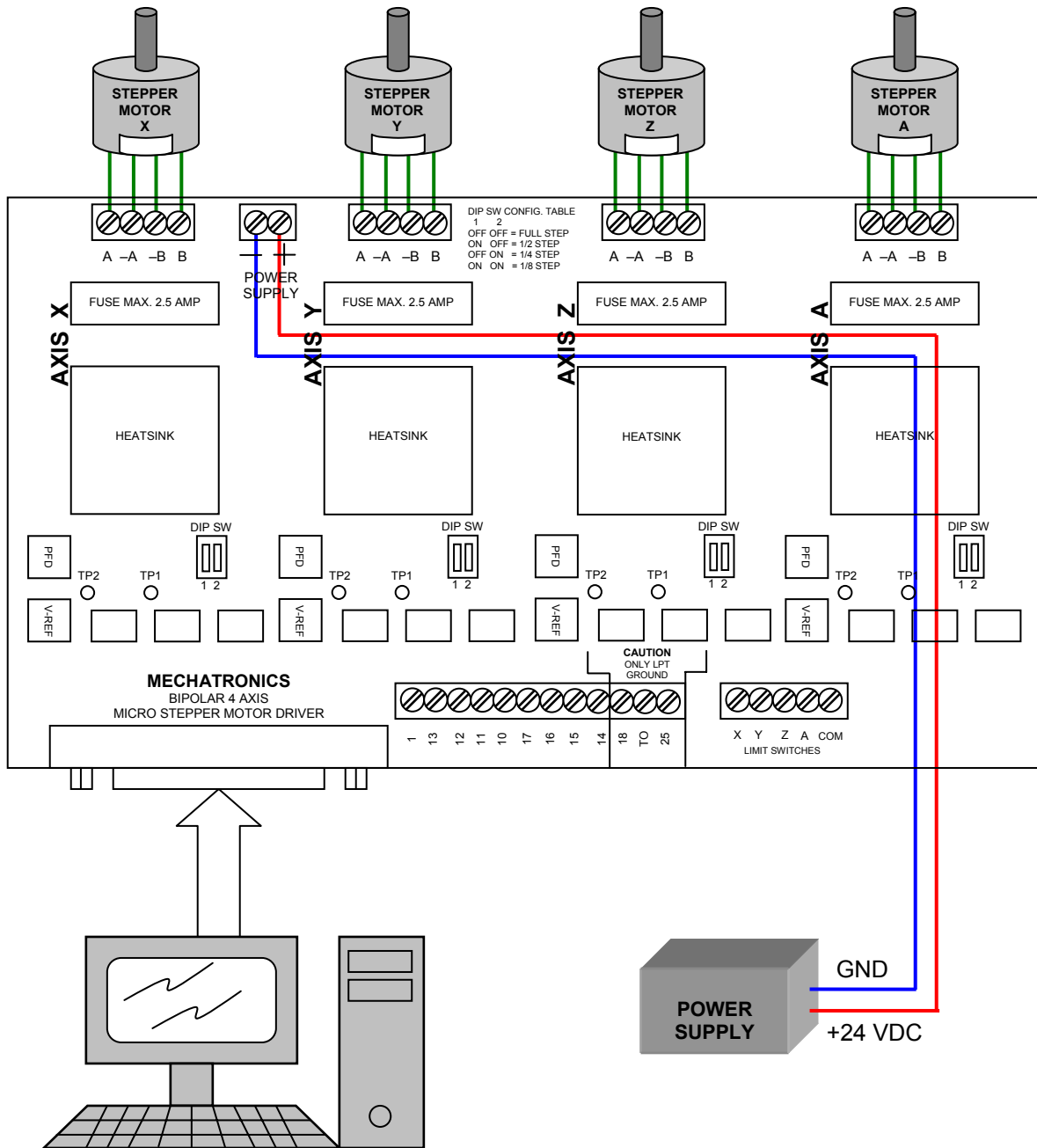

## LIMIT SWITCH CONNECTIONS

The limit switches are used to disable the electrical current in the stepper motor, avoiding incidental damages in the mechanical axes; you can wire them each one to a mechanical switch in you machine.

They are placed in both extreme of each axis, if the mechanical system active one of these switches the corresponding motor will be automatically disabled, you need to deactivate the switch to move again the motor.

Keep in mind that these limit switches has been implemented **via hardware**, is not possible to control them via software, if you want to enable/disable them via software you have to check your favourite CAM software for this.

**Note: The power supply GND disable the limit switches, for any reason this terminal should not be interconnected to the LPT GND.**

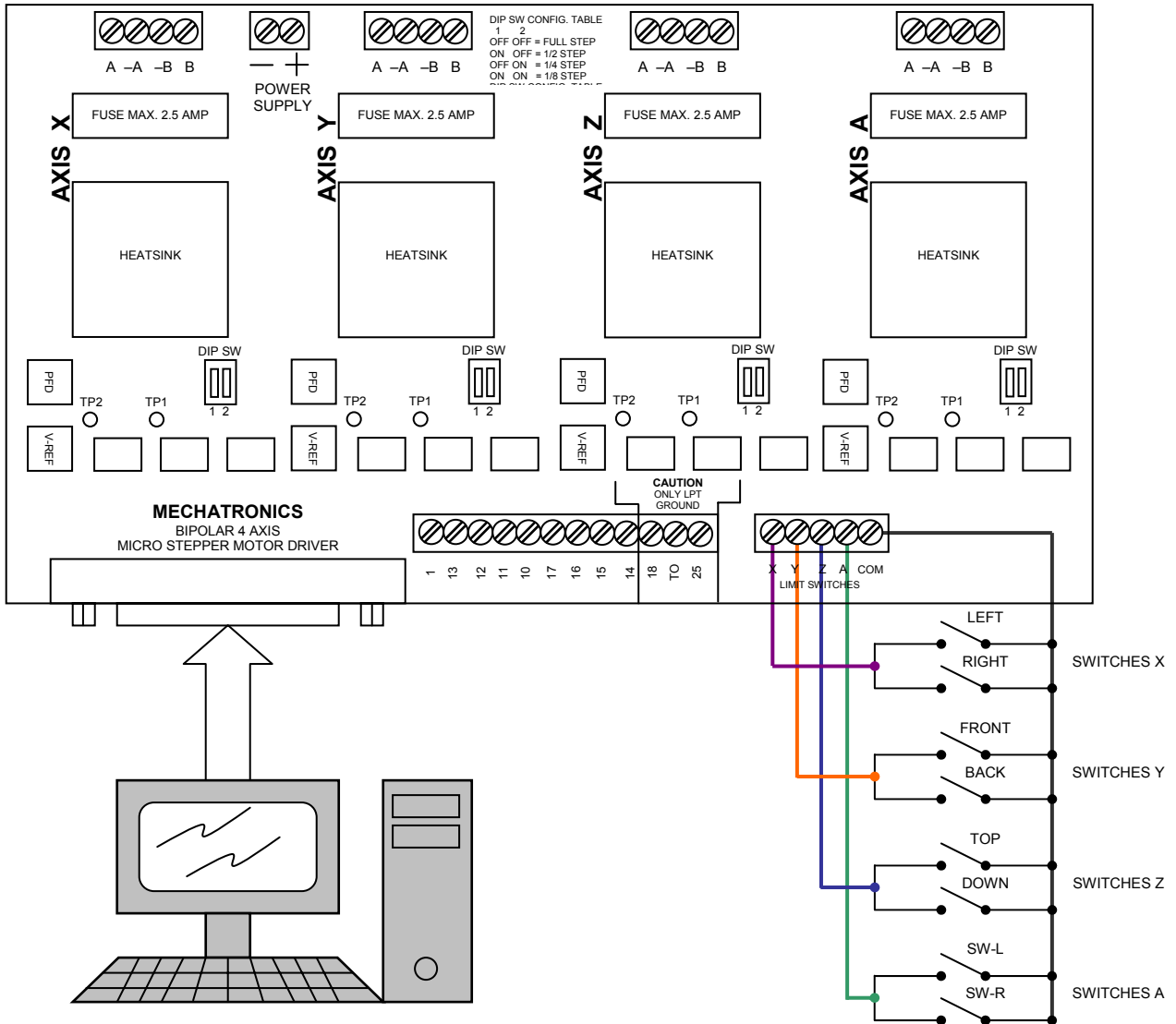

## RELAY BOARD CONNECTION WITH 4 AXIS BOARD

The relay board is used to operate (from the PC with your favourite CAM program) tools that work at 120VAC or 220VAC as a motor tool router, coolant pumps, etc. Without any fear of risk the PC parallel port, because this connection is totally optocoupled.

The CAM software sends a trigger signal through the DB25 breakout terminal blocks to the relay board. The relay board optocouplers switches on the relay that works as 120VAC or 220VAC circuit switches.

**Every relay can close electrical circuits at 125VAC@15Amp or 250VAC@10Amp as maximum.**

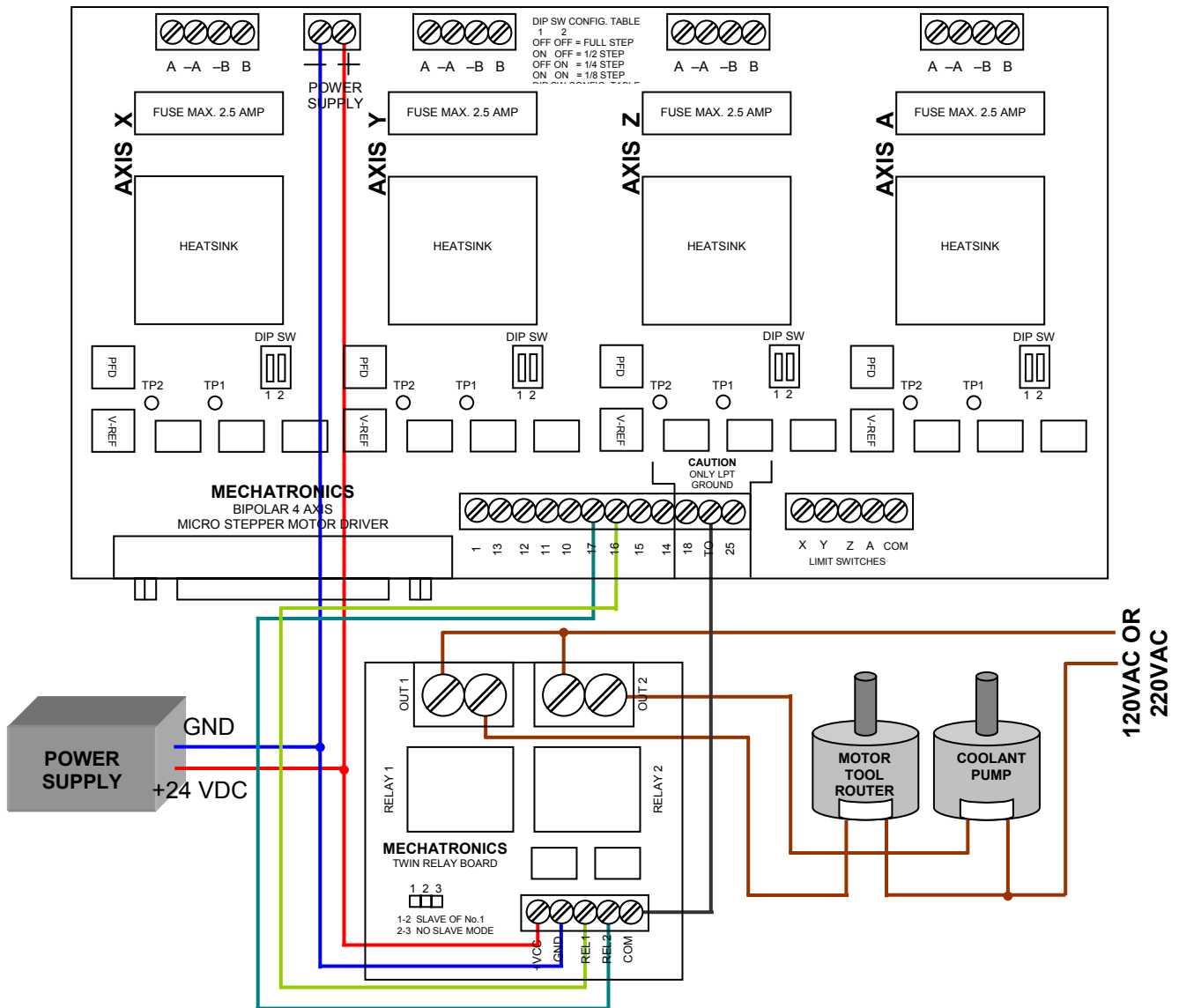

The relay board power supply can be the same of the driver board's power supply; otherwise you can use an independent power supply from 12VDC to 35VDC, as maximum, to feed the drive board. For further information about how to connect the Relay Board, check the Relay Board Datasheet available in our website.

# COMPLETE SYSTEM: 4 AXIS BOARD AND RELAY BOARD

